

INTEGRATING MATHEMATICAL OPTIMIZATION IN DEVS FOR NUCLEAR MEDICINE PATIENT AND RESOURCE SCHEDULING

Eduardo Pérez

Ingram School of Engineering
Department of Industrial Engineering
Texas State University
601 University Dr.
San Marcos, TX 78666, USA

ABSTRACT

Nuclear medicine is a subspecialty of radiology that uses advanced technology and radiopharmaceuticals for the diagnosis and treatment of medical conditions. Procedures in nuclear medicine require the use of radiopharmaceuticals, are multi-step, and have to be performed under strict time windows constraints. These characteristics make the scheduling of patients and resources in nuclear medicine challenging. In this work, we integrate DEVS and CPLEX, a mathematical programming optimization software, to develop a simulation-optimization scheduling methodology for nuclear medicine clinics. We report on computational results of the new model based on a real clinic, historical data, and both patient and management performance measures. The results show that new methodology provides on average an increase of 3% on patient throughput and a decrease of 20% on patient waiting time over a scheduling policy that was used in the clinic in the past.

1 INTRODUCTION

Medical imaging has become a major factor in the total cost of U.S. healthcare (Wing et al. 2007). Physicians are requesting medical diagnosis procedures more often and most of them are done in radiology. Nuclear medicine is a subspecialty of radiology that uses advanced technology and radiopharmaceuticals for the diagnosis and treatment of diseases. The high fixed cost of the technology used in nuclear medicine puts pressure on facility managers to schedule a high volume of patients each day (Gupta and Denton 2008).

However, scheduling patients, radio-pharmaceuticals, and resources in nuclear medicine clinics remains a challenging problem. Resources include equipment such as gamma cameras and tread- mills, as well as human resources such as technologists, nurses, physicians, and EKG technicians.

Nuclear medicine procedures are multi-step, require multiple resources at each step, and require the administration of a radiopharmaceutical to the patient. Radiopharmaceuticals are prepared by request in a nuclear medicine pharmacy and should be scheduled in such a way that they arrive on time. In most of the diagnosis procedures, a scan of the patient is performed. Images of the patients are obtained using gamma cameras that sense the radiation emitted by the radiopharmaceutical. Scheduling patients in nuclear medicine require very strict procedure protocols, which if not followed can result in poor scans and ultimately rescheduling the patient for another day.

In this paper, we consider a discrete event specification (DEVS) model that invokes a software optimization package for solving a mathematical programming model that schedules patient and resources in nuclear medicine. We use the Parallel DEVS formalism (Zeigler and Sarjoughian 2003) to design the new atomic model. The DEVS atomic model we devise is an extension of the Parallel DEVS scheduler

(SCHED) model presented in (Pérez et al. 2010). We incorporate the new DEVS scheduler model to simulate the scheduling of patients and resources and its impact on the system performance. We compare the system performance using the new scheduler atomic model with the fixed-resource (FR) algorithm presented in (Pérez et al. 2010; Pérez et al. 2011).

Parallel DEVS is a revision of the classical DEVS formalism (Zeigler and Sarjoughian 2003). This formalism uses a hierarchical approach to build models. The modeler first defines the basic or atomic models and then uses these atomic models to create coupled (composite) models. A formal specification of Parallel DEVS is provided in (Zeigler and Sarjoughian 2003). Mathematically, a Parallel DEVS model has the following structure:

$$DEVS = (X_M, Y_M, S, \delta_{ext}, \delta_{int}, \lambda, ta) \quad (1)$$

where X_M is the set of input ports and values; Y_M is the set of output ports and values, S is the set of state values; λ is the output function; and ta is the time advance function. These functions define the system dynamics.

$\delta_{ext}: Q \times X_M^b \rightarrow S$ is the external transition function, where X_M^b is a set of bags over elements in X_M and Q is the set of total states. Note that a bag is a set with possible multiple occurrences of its elements. $\delta_{int}: S \rightarrow S$ is the internal state transition function and $\delta_{con}: Q \times X_M^b \rightarrow S$ is the confluent transition function. The structure defined in (1) can be interpreted as follows: when the system is in a state s and no external events occur, the system will not change state for a time $ta(s) \in [0, \infty]$. If the time expires the system outputs the value, $\lambda(s)$, and changes to state $s' = \delta_{int}(s)$. An output is generated only after an internal transition. The external transition function dictates the system's new state when an external event occurs while the internal transition function dictates the system's new state when no events occurred since the last transition. The confluent function decides the next state in cases of collision between external and internal events.

The work reported in the literature on patient service management in nuclear medicine is very limited. Most of the literature focuses on scheduling in model of a hospital radiology department to predict the effects of scheduling policies on the efficiency of the appointment system, as measured by the average patient queueing time and doctor idle time during the day. Johannes and Wayside (Johannes and Wyskida 1978) developed a model for scheduling patients and clinical instruments in a nuclear medicine department that minimizes the equipment idle time. The authors tested a shortest-processing-time-first rule to schedule several patient classes in a nuclear medicine department using simulation. Only a limited number of procedures were studied and their heuristic assumes that the patient to be schedules are known at the beginning of the day. Other work on the use of simulation to analyze staff allocations to improve patient flow in radiology clinics include (O'Kane 1981; Klafehn 1987; Ramakrishnan et al. 2004; Mocarzel et al. 2013; Sowle et al. 2014; Walker et al. 2015). We refer the reader to a survey on the application of discrete-event simulation in healthcare outpatient clinics by (Jun et al. 1999).

The rest of the paper is organized as follows. In Section 2 we describe the overall nuclear medicine simulation model and present a formal description of the new DEVS scheduler atomic model in Section 3. We report preliminary simulation results based on an implementation of the simulation in DEVSSJAVA (Zeigler and Sarjoughian 2003) in Section 4. We end the paper with some concluding remarks in Section 5.

2 THE NUCLEAR MEDICINE SIMULATION MODEL

A nuclear medicine clinic at an abstract level contains multiple entities that interact following the nuclear medicine protocols of the medical procedures. These entities can be classified as human resources (staff),

stations, radiopharmaceuticals, and patients. The appointments provided to the patients dictates the actions and location of most of these entities during the simulation run. The DEVS nuclear medicine simulation considered in this paper comprises several components as show in Figure 1.

The new scheduler model (OPT-SCHED) is part of the experimental frame (EF) of the simulation model. The EF allows the modeler to specify the experiments that will be performed using the simulation to answer the questions of interest. Besides the OPT-SCHED model the EF contains the CGENR, RPGENR, PGENR, and TRANSD atomic models. The CGENR is an atomic model that represents a call center and oversees generating patient appointment requests. The OPT-SCHED model is used to schedule patients into the system and will be discussed in detail in Section 3. The patient appointment information is passed from the OPT-SCHED to the RPGENR and PGENR atomic models. RP-GENR generates the radiopharmaceutical arrivals to clinic at specified times. PGENR generates the patient arrivals to the clinic at their appointment times. The TRANSD computes the performance measures of interest for the nuclear medicine system such as number of patients served, equipment and human resource utilization, and the patient waiting time from the time of the request until the time of the appointment.

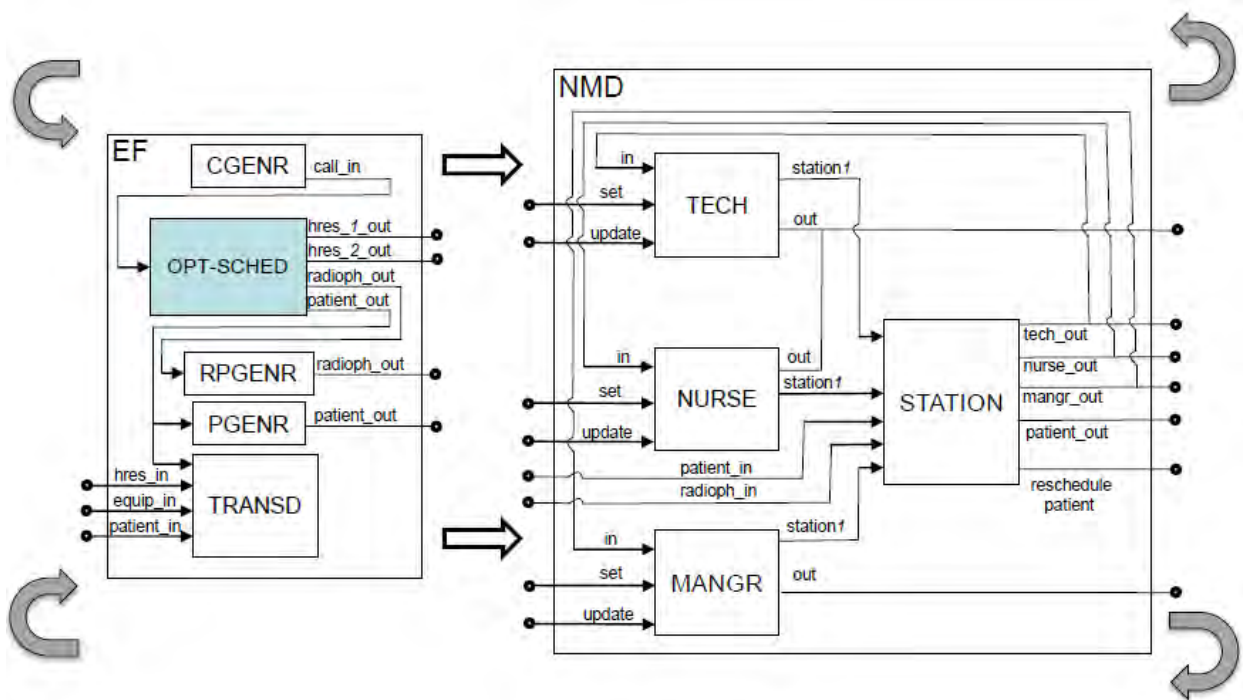

Figure 1: The nuclear medicine department model components.

The NMD coupled model is an abstraction of the nuclear medicine department (NMD) and is created by coupling the human resource atomic models (TECH, NURSE, MANGR, PHYSN) to STATION. In Figure 1, we only show the atomic models for TECH, NURSE, and MANGR due to limitation in the size of the figure. The EF provides input to the NMD model and after entities are served, the NMD provides input the EF model.

3 THE ATOMIC MODEL APPOINTMENT SCHEDULING OPTIMIZATION

The OPT-SCHED atomic model finds an appointment for the patient by looking at the availability of the resources required to perform a procedure. This model provides a framework that allows the user to implement the scheduling algorithm or policy of their choice. In this work, we implement a scheduling

algorithm that uses mathematical programming to find an optimal appointment for the patient. The OPT-SCHED atomic model is shown in Figure 2.

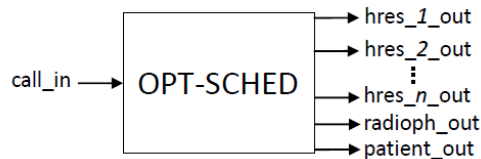

Figure 2: A OPT-SCHED atomic model.

The block diagram depicts the input and out-put ports of the model. There is only one in-put port, named “call_in” and three types of out-put ports, namely; “patient_out”, “radioph_out” and “hres_x_out”. The number of outpost ports of type “hres_x_out” depends on the number of human resources at the nuclear medicine facility. The “call_in” input port receives messages that contain the information of the patients requesting a nuclear medicine procedure. Once an appointment is found for the patient, the model sends three different message types through the output ports. The first type of message is sent to the human resources scheduler to serve the patient request on hand through the “hres_x_out” output port. Every human resource assigned to serve this patient will receive a message to update their current schedule. The other two message types are sent to the atomic models in charge of generating patient and radiopharmaceutical arrivals to the system when the time of an appointment arrives. The “patient_out” output port sends information to the patient generator (PGENR) atomic model and the “radioph_out” output port sends information to the radiopharmaceutical generator (RPGENR) atomic model.

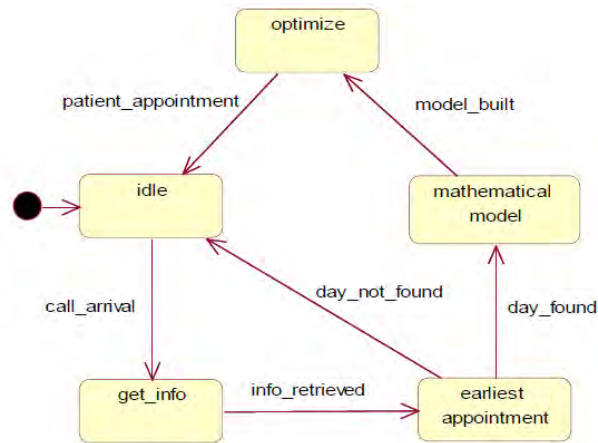

Figure 3: State transition diagram for OPT-SCHED atomic model.

The operation of the OPT-SCHED atomic model is depicted in Figure 3. The model has five basic states: “idle”, “get info”, “earliest appointment”, “mathematical model”, and “optimize”. The model is initialized in the “idle” state. The model transitions to the “get info” “earliest appointment” state. In this state a method named get Day () finds the earliest day in which the appointment can be scheduled. If a day is found, the model transitions to the “mathematical model” state. In this state the model invokes ILOG CPLEX which is a software package for solving mathematical problems using optimization. The OPT-SCHED atomic model creates an object of type IloCplex and uses the Concert Technology modeling interface implemented by ILOG CPLEX to create the mathematical model for the scheduling problem. Figure 4 illustrates how the OPT-SCHED atomic model uses Concert Technology, the object of

type IloCplex, and the CPLEX software. Once the IloCplex is created in the ILOG CPLEX software environment the Concert Technology Interface passes the information needed to build the mathematical model for the scheduling problem.

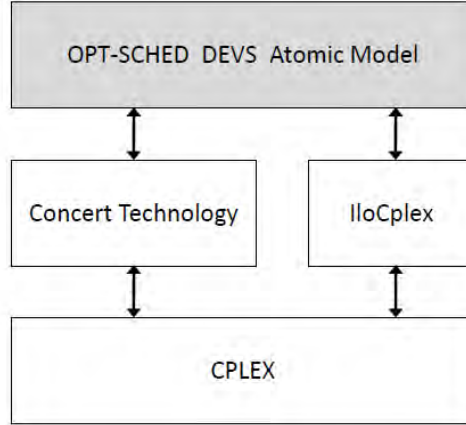

Figure 4: Interface for mathematical model.

After building the mathematical model the OPT- SCHED atomic model transitions to the “optimize” state. In this state the mathematical model for the scheduling problem is solved using CPLEX and the solution is passed back to the OPT-SCHED atomic model using the Concert Technology interface. The solution is then used to identify the resources seized to serve the current patient and to determine the appointment starting time. This information is used to generate the corresponding outputs. After the outputs are generated the model transitions back to the “idle” state.

We describe the OPT-SCHED atomic model mathematically using Parallel DEVS. In what follows, $call_i$ contains the information of patient i making the request, p info is used to save the information needed to schedule the patient. The atomic model can be expressed in Parallel DEVS as follows:

$$DEVS_{OPT-SCHED} = (X_M, Y_M, S, \delta_{ext}, \delta_{int}, \lambda, ta)$$

where,

$$X_M = \{(p, v) | p \in IPorts, v \in X_p\}$$

is the set of input ports and values, $IPorts = \{“call_in”\}$, and $X_{call_in} = V_1$ is an arbitrary set.

The set

$$Y_M = \{(p, v) | p \in OPorts, v \in Y_p\}$$

is the set of output ports and values, and $OPorts = \{“patient_out”, “radioph_out”, “hres_1_out”, “hres_2_out”, \dots, “hres_n_out”\}$, where $Y_{patient_out}, Y_{radioph_out}, Y_{hres_1_out}, Y_{hres_2_out}, \dots, Y_{hres_n_out}$ are arbitrary sets. The $S = \{“idle”, “get_info”, “earliest_appointment”, “mathematical_model”, “optimize”\} \times \mathfrak{R}_{+,0} \times V_1$ is the set of sequential states.

External Transition Function:

$$\begin{aligned} \delta_{ext}((phase, \sigma, call_i), e, (p, v)) \\ &= (“scheduling”, $t_s, call_i$), if $phase == “idle” \wedge p == “call_in”, p_info = getPatientInfo(call_i)$; \\ &= $(phase, \sigma - e, call_i)$, otherwise. \end{aligned}$$

Internal Transition Function:

$$\begin{aligned} \delta_{int}((phase, \sigma, p_info), e, (p, v)) \\ &= (\text{"earliest_appointment"}, t_e, p_info), \text{ if } phase == \text{"get_info"}; \\ &= (\text{"mathematical_model"}, t_m, p_info), \text{ if } phase == \text{"earliest_appointment"} \wedge search = true; \\ &= (\text{"optimize"}, t_0, p_info), \text{ if } phase == \text{"mathematical_model"} \wedge search = false; \\ &= (\text{"idle"}, \infty), \text{ if } phase == \text{"earliest_appointment"} \wedge search = false; \\ &= (\text{"idle"}, \infty), \text{ if } phase == \text{"optimize"} \end{aligned}$$

Confluence Function:

$$\delta_{con}(s, ta(s), x) = \delta_{ext}(\delta_{in}(s), 0, x).$$

Output Function:

$$\begin{aligned} \lambda(phase, \sigma, call_i) \\ &= (patient_out, patient_i), \text{ if } phase == \text{"optimize"}, \text{ where } patient_i \text{ is the message to send to} \\ &\quad \text{PGENR}; \\ &= (radioph_out, radioph_i), \text{ if } phase == \text{"optimize"}, \text{ where } radioph_i \text{ is the message to send to the} \\ &\quad \text{RPGENR}; \\ &= (hres_i_out, msg_i), \text{ if } phase == \text{"optimize"} \wedge hresID == i, \text{ where } msg_i \text{ is the message to send} \\ &\quad \text{to the atomic model for human resource } i = 1, \dots, n. \end{aligned}$$

Time Advance Function:

$$ta(phase, \sigma, call_i) = \sigma.$$

In general, the model will process a request for an appointment by finding the earliest day in which the appointment can be schedule. Then, using that date, a stochastic programming model will be formulated and solve to find the best appointment date and time while considering a forecast of possible requests that might come later.

4 APPLICATION

We implemented the simulation model in DEVS- JAVA and applied the NMD simulation model to the nuclear medicine department of the Scott & White Health System in Temple, Texas, U.S. This is one of the largest nuclear laboratories for general nuclear imaging in the U.S. The clinic operates five days a week from 8:00 am to 5:00 pm, and is not open on weekends.

Human resources	Number
Technologists	8
EKG Technologist	2
Nurse	1
Manager	1

Table 1: Human resources used in the NMD simulation.

The NMD simulation configuration was based on historical data. Table 1 shows human resources considered in the simulation. Table 2 contains the information of the stations used in the simulation model. We assumed that the arrival process of patient requests at the clinic follows a Poisson process. The interarrival times follow an exponential distribution where the means vary per month per the historical data provided by the real clinic.

We compared the system performance using the OPT-SCHED atomic model with the FR algorithm, which is described in detailed in (Pérez et al. 2010). Under the FR scheduling policy two of the technologists of the clinic are fixed to two of the Axis stations of the system. The rest of the staff are available to be scheduled to the other stations as needed. We used the performance measures listed in Table 3 to quantify the system service levels. We used a scheduling horizon of three months with a warm-up period of a month. Different seeds for the random number generators on each replication and we computed the mean and standard deviation for each of the performance measures.

Table 2: Stations used in the NMD simulation.

Station name	Number	Equipment
Axis	3	Philips Axis
P2000	2	Philips PRISM 2000
P3000	1	Philips PRISM 3000
Meridian	1	Philips Meridian
Treadmill	2	Treadmill
TRT	3	Patient Preparation

Table 3: System performance measures.

Name	Description
Waiting time <i>Type 1</i>	Patient waiting time from the time of the request until time of the appointment
Preference satisfaction	Number of times patient request for an appointment is satisfied
Equipment utilization	Ratio of the amount of time equipment is used vs. the amount of time it is available
Human resource utilization	Ratio of the amount of time staff member is busy vs. the amount of time it is available
Patient throughput	Total number of patients served

Next we report the results of the NMD simulation with the OPT-SCHED atomic model and compare them to the FR algorithm. Results for patient throughput, patient preference satisfaction, and patient waiting time are summarized in Table 4. The OPT-SCHED model obtains a better performance for all the system performance measures listed in the table. The number of patient served for a three-month period is 3% higher than the FR algorithm. In terms of the patient preference ratio both scheduling options provide good results but the OPT-SCHED provide a slightly better performance. Patient waiting time is reduced under the OPT-SCHED model implementation.

We present the results for the utilization of the resources using two plots. Figure 5 depicts the utilization of the human resources under both scheduling techniques. The OPT-SCHED model provides a more balanced resource utilization for the human resources. Figure 6 presents the utilization the utilization of the stations in the nuclear medicine facility. Both scheduling techniques provide a similar utilization for most of the station. However, they differ significantly in the utilization of the Meridian (1),

Axis (1), and Axis (2) stations. The OPT-SCHED model tends to schedule more patients in the Meridian (1) station which reduces the utilization of the Axis (1) and Axis (2) stations.

Table 4: Patient throughput, patient preference satisfaction, and patient waiting time.

Scheduling Algorithm	Statistic	Patient throughput	Patient preference	Patient waiting (days)
OPT-SCHED	Mean	2528	99.0%	2.89
	Std. Dev.	7.89	1.7%	0.35
FR	Mean	2456	97.0%	3.61
	Std. Dev.	7.38	1.9%	0.41

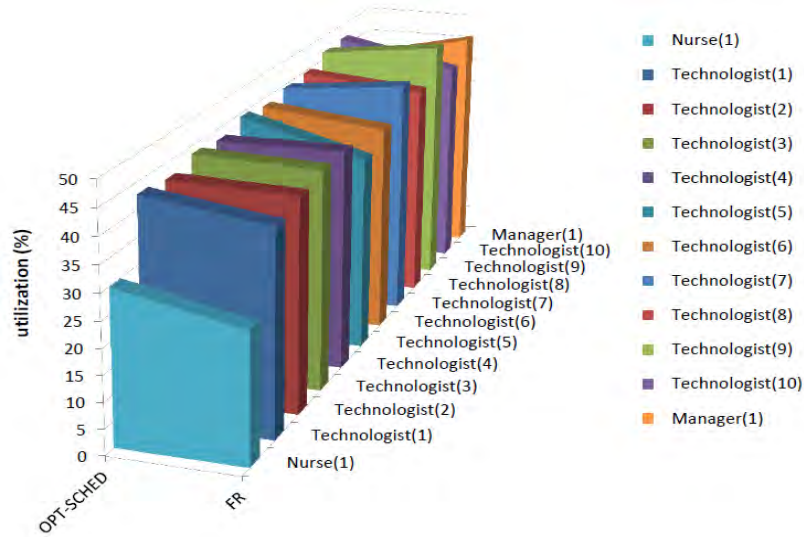

Figure 5: Human resource utilization.

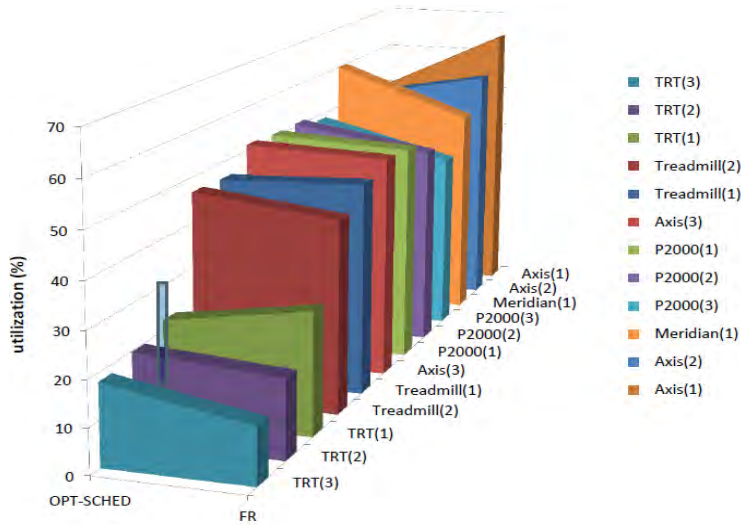

Figure 6: Equipment (station) utilization.

5 CONCLUSION

The increased demand for medical diagnosis procedures has become a major factor in the rise of health-care cost in the U.S. Nuclear medicine is a sub-specialty of radiology that uses new technology and radiopharmaceuticals for the treatment and diagnosis of patients. Scheduling nuclear medicine procedures is a challenging task. These procedures are multi-step and are constrained by strict time window constraints.

In this paper, we consider a DEVS model that schedule patients in nuclear medicine clinics using an optimization software package. We use the Parallel DEVS formalism to design this new model and incorporate the model to the simulation model developed by (Pérez et al. 2010). We compare the performance of the new model with performance of the FR algorithm. The results show that the new OPT-SCHED model provides on average a 3% increase in the number of patients served by the clinic during a three months' period. The OPT-SCHED model also provides a better performance for those performance measures related to patient service such as the preference ratio and patient waiting time

REFERENCES

- Gupta, D., and B. Denton. 2008. "Appointment Scheduling in Health Care: Challenges and Opportunities." *IIE Transactions* 40(9):800-819.
- Johannes, J. D., and R. M. Wyskida. 1978. "A Nuclear Medicine Patient/Instrument Scheduling Model." *Omega* 6(6):523-530.
- Jun, J. B., S. H. Jacobson, and J. R. Swisher. 1999. "Application of Discrete-Event Simulation in Health Care Clinics: A Survey." *The Journal of the Operational Research Society* 50(2):109-123.
- Klafehn, K. A. 1987. "Impact Points in Patient Flows through a Radiology Department Provided through Simulation". In *Proceedings of the 1987 Winter Simulation Conference*, edited by H. Grant, W.D. Kelton, and A. Thesen, 914-918. Piscataway, New Jersey: Institute of Electrical and Electronics Engineers, Inc.
- Mocarzel, B., D. Shelton, B. Uyan, E. Pérez, J. A. Jimenez, and L. DePagter. 2013. "Modeling and Simulation of Patient Admission Services in a Multi-Specialty Outpatient Clinic". In *Proceedings of the 2013 Winter Simulation Conference*, edited by F. Armstrong, J.A. Joines, N. Steiger, and M.E. Kuhl, 2309-2319. Piscataway, New Jersey: Institute of Electrical and Electronics Engineers, Inc.
- O'Kane, S. P. 1981. "A Simulation Model of a Diagnostic Radiology Department." *European Journal of Operational Research* 6(1):38-45.
- Pérez, E., L. Ntaimo, C. Bailey, and P. McCormack. 2010. "Modeling and Simulation of Nuclear Medicine Patient Service Management in DEVS." *Simulation* 86(8-9):481-501.
- Pérez, E., L. Ntaimo, W. E. Wilhelm, C. Bailey, and P. McCormack. 2011. "Patient and Resource Scheduling of Multi-Step Medical Procedures in Nuclear Medicine." *IIE Transactions on Healthcare Systems Engineering* 1(3):168-184.
- Ramakrishnan, S., K. Nagarkar, M. DeGennaro, M. Srihari, A. Courtney, and F. Emick. 2004. "A Study of the CT Scan Area of a Healthcare Provider." In *Proceedings of the 2004 Winter Simulation Conference*, edited by J. Smith, B. Peters, R.G. Ingalls, and M.D. Rossetti, 2025-2031. Piscataway, New Jersey: Institute of Electrical and Electronics Engineers, Inc.
- Sowle, T., N. Gardini, F. V. A. Vazquez, E. Pérez, J. A. Jimenez, and L. DePagter. 2014. "A Simulation-IP Based Tool for Patient Admission Services in a Multi-Specialty Outpatient Clinic". In *Proceedings of the 2014 Winter Simulation Conference* edited by SJ Buckley, J.A. Miller, A. Tolk, L. Yilmaz, S.Y. Diallo, and I.O. Ryzhov, 1186-1197. Piscataway, New Jersey: Institute of Electrical and Electronics Engineers, Inc.

- Walker, D., E. Shanks, D. Montoya, C. Weiman, E. Pérez, and L. DePagter. 2015. "Towards a Simulation Based Methodology for Scheduling Patient and Providers at Outpatient Clinics". In *Proceedings of the 2015 Winter Simulation Conference*, 1515-1524, Piscataway, New Jersey: Institute of Electrical and Electronics Engineers, Inc.
- Wing, P., M. H. Langelier, and A. P. De. 2007. "Nuclear Medicine Scientists: Findings and Recommendations Based on a 2006 Survey." *Journal of Nuclear Medicine* 48(4):11-24.
- Zeigler, B. P., and H. S. Sarjoughian. 2003. "Introduction to DEVS Modeling and Simulation with Java: Developing Component-Based Simulation Models." *Technical Document, University of Arizona*.

AUTHOR BIOGRAPHIES

EDUARDO PEREZ is an Assistant Professor at Texas State University, Ingram School of Engineering, San Marcos, Texas, USA. He obtained his B.S. in Industrial Engineering from the University of Puerto Rico, Mayagüez Campus and his Ph.D. in Industrial Engineering from Texas A&M University. His research interests include healthcare systems engineering and analysis, patient and resource scheduling, and optimization and simulation techniques. He is a member of INFORMS, IIE, and Tau Beta Phi. His email address is eduardopr@txstate.edu.