

## **SIMULATION AND OPTIMIZATION OF ENERGY EFFICIENT OPERATION OF HVAC SYSTEM AS DEMAND RESPONSE WITH DISTRIBUTED ENERGY RESOURCES**

Young M. Lee  
Raya Horesh

Leo Liberti

IBM Research  
IBM T.J. Watson Research Center  
110 Kitchawan Road  
Yorktown Heights, NY 10598, USA

CNRS LIX  
École Polytechnique  
F-91128  
Palaiseau, FRANCE

### **ABSTRACT**

Optimal control of building's HVAC (Heating Ventilation and Air Conditioning) system as a demand response may not only reduce energy cost in buildings, but also reduce energy production in grid, stabilize energy grid and promote smart grid. In this paper, we describe a model predictive control (MPC) framework that optimally determines control profiles of the HVAC system as demand response. A Nonlinear Autoregressive Neural Network (NARNET) is used to model the thermal behavior of the building zone and to simulate various HVAC control strategies. The optimal control problem is formulated as a Mixed-Integer Non-Linear Programming (MINLP) problem and it is used to compute the optimal control profile that minimizes the total energy costs of powering HVAC system considering dynamic demand response signal, on-site energy storage system and energy generation system while satisfying thermal comfort of building occupants within the physical limitation of HVAC equipment, on-site energy storage and generation systems.

### **1 INTRODUCTION**

In most countries, buildings (commercial and residential) consume more than 40% of the total energy, and HVAC (Heating Ventilation and Air Conditioning) systems consume 50% of the building energy consumption. Therefore, 20% (i.e., 40% x 50%) of the total energy consumption in the world is for HVAC operations. A recent study by Zavala, Celinski and Dickinson (2011) indicates that optimal control of HVAC system can achieve energy savings of up to 45%. Therefore, 9% of overall energy savings in the world can be achieved by optimal control of HVAC system. Optimal control of building HVAC is also considered to be the biggest Demand Response (DR) opportunity that can reduce energy consumption, grid energy production, stabilize energy grid and promote Smart grid.

In this paper, we describe a Model Predictive Control (MPC) framework that optimally computes the control profiles of the HVAC system as well as how the power (load) needed by the HVAC system is optimally sourced through optimized combination of grid purchased energy with DR, on-site stored energy and on-site generated energy. The optimal control profile then can be communicated to the controller (i.e., Building Automation System) to control HVAC system. The method can reduce energy costs of HVAC operations proactively considering the price of grid purchased electricity, on-site stored electricity and on-site generated energy. The resulting tool can serve as an energy reduction and demand response tool that not only optimizes the energy costs in buildings but also reduces energy production and stabilize energy supply (grid).

Traditional approach for optimized HVAC control in building is to compute optimal control profile (e.g., set point profile of heating/cooling zone, or supply flow rate of air handling unit (AHU)) that minimizes the total energy consumption while satisfying thermal comfort (e.g., zone temperature) and physical limitation of HVAC equipment (e.g., supply temperature and supply flow rate of AHU). An examples of this approach are shown by Braun, Montgomery and Chaturvedi (2001) and Braun (1990), who developed optimal HVAC Control method using building thermal mass for energy load shaping and peak reduction. The traditional approaches typically assume that the electricity price is constant throughout the day.

Ever since DR became an important means to balance energy demand and supply, there have been new approaches to HVAC control, that compute optimal profiles while minimizing the total energy costs subject to DR signal (dynamic electricity price). These approaches have been described by e.g. Zavala, Celinski and Dickinson (2011) and Zavala, Zimmerman and Ott (2011). However, these approaches do not decide how the load of HVAC system resulting from the optimized control is optimally sourced through multiple energy supplies, e.g., grid electricity with DR, on-site stored electricity and on-site generated electricity. There has been prior research on management of energy generation, including the work by Kusiak and Guanglin (2012), who developed a MINLP for the optimal design and dispatch of distributed generation systems. The MINLP by Kusiak and Guanglin (2012) assumes that energy demand is given and does not integrate the energy demand control (e.g., HVAC control) with the energy storage decision: the authors focus on optimized dispatching (operational) decision on energy storage and generation. The approach described in this paper computes optimal HVAC control profile that minimizes the total energy costs and GHG emission, considering (1) DR signal, (2) on-site energy storage system (3) on-site energy generation system while satisfying thermal comfort (e.g., zone temperature), physical limitations of HVAC equipment, and physical limitation of energy storage system (ESS) and energy generation system (EGS). Our approach determines not only the optimal control profile but also how to power the HVAC system from the optimal combination of grid electricity, on-site stored electricity and on-site generated electricity.

In this MPC framework, the thermal behavior of the building zone described above is modeled by a NARNET and the optimal control problem is formulated as a MINLP model. We used a U.S. Department of Energy (DOE) reference building to simulate several HVAC control strategies and generated the data to be used for developing the thermal behavior model using EnergyPlus (EnergyPlus 2015). The reference building is a three story, medium office building in Baltimore MD, USA, Climate Zone 4A, and TMY (typical meteorological year) data (NREL 2008) was used. We simulated several different HVAC control strategies including night setup, demand limiting and pre-cooling strategy (Braun, Montgomery and Chaturvedi 2001; Lee and Braun 2004), with zone set point as the control variables. The data was simulated for one year with 10 minutes interval, and used for analysis and modeling.

## **2 APPROACH, SIMULATION AND DATA**

A simplified view of heat transfer in a building that we are developing a model for is shown in Figure 1. Building occupants can have influence on comfortable climate condition decision, such as temperature and humidity inside the building. However, because buildings are neither perfectly insulated nor blocked from sunlight, warm and humid climate conditions outside a building influence the building's indoor climate during the summer season, and cold and dry air enters the building during the winter season, making the inside climate uncomfortable for the occupants. In order to compensate for the influence of the outside climate, HVAC system and plant equipment (e.g., chillers and boilers) are operated to provide thermal energy into the building to maintain occupants' thermal comfort. Typically, heat transfer from outdoor conditions into the indoor space involves heat transfer through a building component like external or internal walls, windows, the roof, and the ground (foundation). The heat transfer includes heat conduction (e.g., heat flows through wall materials), heat convection (e.g., heat flows through the air from

interior walls into the space), solar radiation (e.g., solar energy on the exterior wall or through openings such as a window onto an interior wall), air infiltration through space through cracks around windows, doors, and opened windows and doors, and internal heat gain from light, equipment, and occupants. The plant and its systems produce thermal energy sources such as steam, hot water, or chilled water, which is then transferred to the internal space of the building through the system equipment. In the case of an all-air-based system, heat exchangers convert the source energy into warm and cold air with a certain supply temperature, humidity, and flow rate, and blow them to each zone of the building using AHUs and other fan systems.

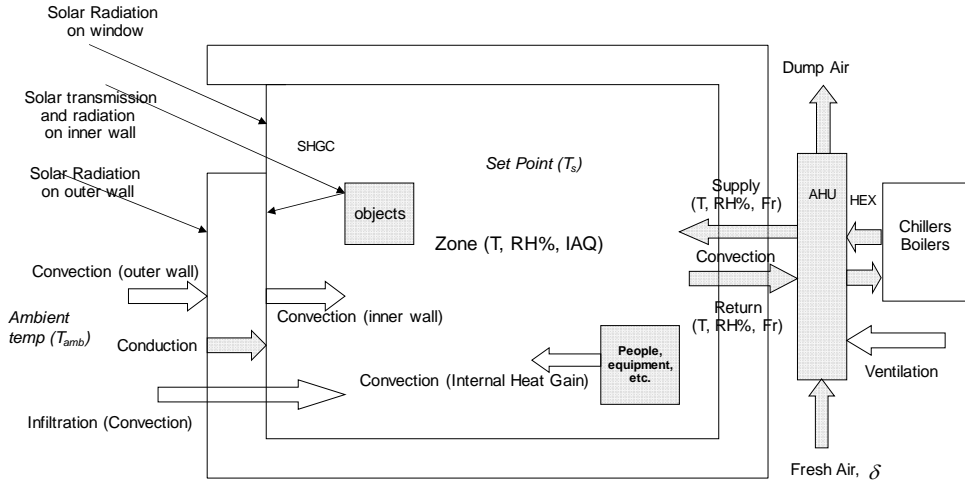

Figure 1: Schematic view of heat transfer in a building.

In this model predictive control (MPC) framework, the thermal behavior of the building zone described above is modeled by a Nonlinear Autoregressive Neural Network (NARNET) and the optimal control problem is formulated as a Mixed-Integer Non-Linear Programming (MINLP) model. We used a U.S. Department of Energy (DOE) reference building, in EnergyPlus (EnergyPlus 2015) and simulated several HVAC control strategies and generated the data for developing the thermal behavior model. In addition, we simulated data for 1 year period in 10 minutes interval, that was used for analysis and modeling. The simulation results for different control strategies clearly indicate that different control strategies make significant impact on energy consumption, peak energy consumption, time of the peak load and energy costs and a good optima control tool can identify opportunities for significant energy cost savings opportunities. Our optimal control method in the subsequent section below dynamically computes the control profile that minimizes the energy costs in various situations.

### 3 MATHEMATICAL MODEL FOR THERMAL BEHAVIOR IN BUILDING

The thermal behavior in a building can be represented by:

$$x_t = f(x_{t-1}, x_{t-2}, \dots, u_t, u_{t-1}, u_{t-2}, \dots, e_t, e_{t-1}, e_{t-2}, \dots) \quad (1)$$

where  $x_t$  is the state variable at time  $t$ ,  $u_t$  is the control variable at time  $t$  and  $e_t$  are the external inputs at time  $t$ . As shown in Equation 1, the state variable at current step depends on the state variables in previous steps, as well as control variables and external inputs at current and previous time steps. State, control and external inputs could be vectors that account for multiple components. Examples of state variables include the zone temperature of zone  $z$  at time  $t$ ,  $T_{t,z}^{zone}$ . Examples of external inputs include the day of the week (DOW) indicator, the time of the day (TOD) indicator and the ambient temperature,

$T_t^{amb}$ . Examples of control variables include  $T_{t,z}^{SP}$ , the set point for zone  $z$  at time  $t$ , the supply temperature of AHU at zone  $z$ , and the supply flow rate of AHU at zone  $z$ . For the example of state variable  $T_{t,z}^{zone}$  and control variable  $T_{t,z}^{SP}$ , the state variable equation (1) becomes:

$$T_{t,z}^{zone} = f(T_{t-1,z}^{zone}, T_{t-2,z}^{zone}, \dots, \bar{x}_t, \bar{x}_{t-1}, \bar{x}_{t-2}, \dots, T_{t,z}^{SP}, T_{t-1,z}^{SP}, T_{t-2,z}^{SP}, \dots) \quad (2)$$

where  $\bar{x}$  are external inputs such as DOW, TOD and ambient temperature,  $T_t^{amb}$ . Equation 1 and 2 are referred to as equations of system state.

The thermal phenomena of zones in a building can also be described by means of the system output. An example of system output variable is  $P_{t,z}^{HVAC}$ , power consumption of HVAC system for zone  $z$  at time  $t$  as shown in Equation 3.

$$P_{t,z}^{HVAC} = h(P_{t-1,z}^{HVAC}, P_{t-2,z}^{HVAC}, \dots, T_{t,z}^{zone}, T_{t-1,z}^{zone}, T_{t-2,z}^{zone}, \dots, \bar{x}_t, \bar{x}_{t-1}, \bar{x}_{t-2}, \dots, T_{t,z}^{SP}, T_{t-1,z}^{SP}, T_{t-2,z}^{SP}, \dots) \quad (3)$$

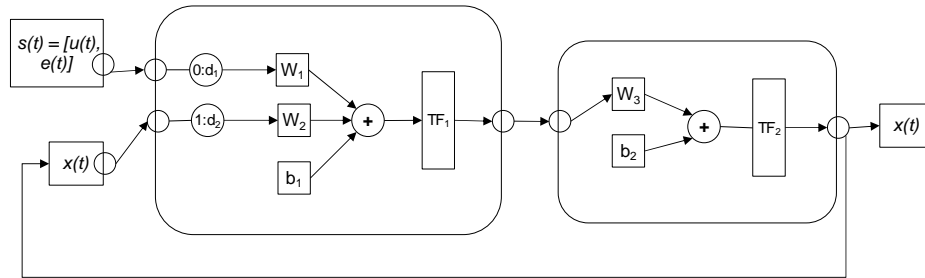

Figure 2: NARX model for thermal behavior of building.

Artificial neural networks (ANN) (Anderson 1995) are a well-known method for modeling the thermal behavior (Equation 2 and 3) of the building zone. As HVAC system behavior is usually dynamic and non-linear, one can employ a non-linear autoregressive data driven model with external input (NARX) in order to capture its properties and states. The neural network model is also called Nonlinear Autoregressive Neural Network (NARNET). NARX is a feed-forward time delay neural network, which maps input data to an output, using additional external input (see Figure 2). The NARX network includes three layers: input layer, hidden layer and output layer (deep NARX networks with multiple hidden layers can also be considered). The control problem is modeled by means of Mathematical Programming (MP), a formal language to describe optimization problems. The decision variables are control and state variables; the constraints describe system behavior, and the objective function minimizes costs. MP requires all functions appearing in constraints and objectives to be expressed in closed form, which is not the case for Equation 1-3. However, ANN dynamics are essentially linear, followed by a usually nonlinear activation function. We therefore replace Equation 1-3 by the closed form equations of the ANN dynamics, yielding, in general, a Mixed-Integer Nonlinear Program (MINLP). The choice of the activation function influences the extent to which this MINLP involves integer variables and nonlinear terms. Various types of activation functions such as hyperbolic tangent sigmoid transfer function (tansig), symmetric saturated liner transfer function (satlins) and hard-limit transfer function (hardlins) can be used. Choosing the discrete approximations satlins and hardlins results in a Mixed-Integer Linear Programming (MILP) problem, which is easier to solve. The ANN is trained on historic time-series data (e.g., few weeks' time series data). The entire dataset for neural network training may be randomly divided into three contiguous blocks: training, validation and testing.

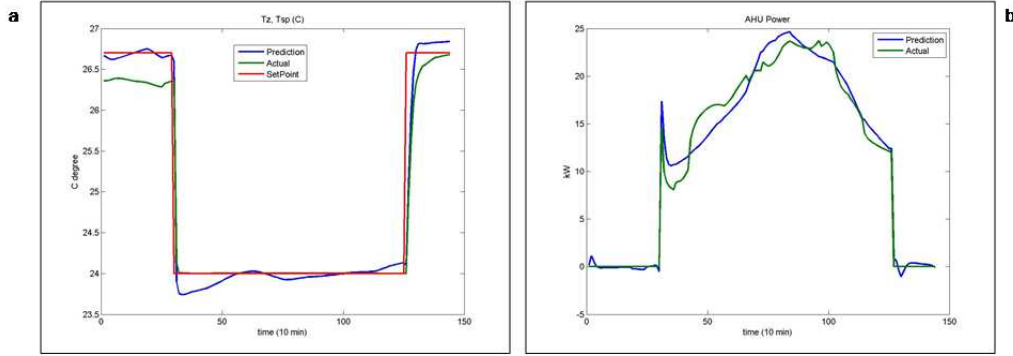

Figure 3: NARX model prediction: (a) zone temperature (b) zone power.

This network described in Figure 1 results in the following algebraic equation:

$$x(t) = F_2[W_3 \cdot F_1\{W_1 \cdot (s(t), s(t-1), \dots, s(t-d_1)) + W_2 \cdot (x(t-1), \dots, x(t-d_2)) + b_1\} + b_2] \quad (4)$$

where  $W_1, W_2, W_3$  are weight matrices,  $b_1, b_2$  are biases,  $d_1, d_2$  are network time delays and  $F_1, F_2$  are transfer functions, of which  $F_2$  is usually chosen to be linear.  $s(t)$  is the network input (array of input that include both the control and external variables) at time  $t$  and  $x(t)$  is the network output (e.g., zone temperature or power).

The NARX model predictions (with satlins transfer function) are compared with simulated data in Figure 3 for a day in August, and the prediction accuracy is reasonably good. The zone temperature model (Equation 2) prediction has mean absolute error (MAE) of 0.147, mean squared error (MSE) of 0.038, root mean squared error (RMSE) of 0.195, coefficient of variation (CV) of RMSE of 0.007868 and mean bias error of 0.00283. The power model (Equation 3) prediction for the day is MAE of 1.017, MSE of 1.811, RMSE of 1.345, CV(RMSE) of 0.114 and MBE of 0.00758.

#### 4 MODEL PREDICTIVE CONTROL OF HVAC SYSTEM

The model predictive control of HVAC system is formulated as a MINLP with the following objective function (Equation 5), and constraints (Equation 6-9). Our solution is also subject to other physical constraints of the HVAC system, the energy storage system (ESS), and the energy generation system (EGS), not shown here for lack of space.

$$\min_{p_t, s_t^{in}, s_t^{out}, g_t, T_{t,z}^{sp}} \sum_{t \in T, z \in Z} [\alpha_1 \{C_t^e (p_t + \frac{S_{in}}{\lambda^s}) + C^g \frac{g_t}{\lambda^g}\} + \alpha_2 \{G_t^e (p_t + \frac{S_{in}}{\lambda^s}) + G^g \frac{g_t}{\lambda^g}\} + \alpha_3 \sum_{t \in T, z \in Z} |T_t^{zone*} - T_{t,z}^{zone}|] \quad (5)$$

The objective function is subject to the ANN closed form which approximates  $f$  and  $h$  in Equations 6,7 and to Equations 8,9 below:

$$T_{t,z}^{zone} = f(T_{t-1,z}^{zone}, T_{t-2,z}^{zone}, \dots, \bar{x}_{t-1}, \bar{x}_{t-2}, \dots, T_{t,z}^{sp}, T_{t-1,z}^{sp}, T_{t-2,z}^{sp}, \dots), \quad \forall t \in T, z \in Z \quad (6)$$

$$P_{t,z}^{HVAC} = h(P_{t-1,z}^{HVAC}, P_{t-2,z}^{HVAC}, \dots, T_{t,z}^{zone}, T_{t-1,z}^{zone}, T_{t-2,z}^{zone}, \dots, \bar{x}_{t-1}, \bar{x}_{t-2}, \dots, T_{t,z}^{sp}, T_{t-1,z}^{sp}, T_{t-2,z}^{sp}, \dots), \quad \forall t \in T, z \in Z \quad (7)$$

$$\sum_{z \in Z} P_{t,z}^{HVAC} = p_t + s_t^{out} \lambda^d + g_t, \quad \forall t \in T \quad (8)$$

$$T_{t,z}^{zone,L} \leq T_{t,z}^{zone} \leq T_{t,z}^{zone,H}, \quad \forall t \in \{t_L \leq t \leq t_H\} \quad (9)$$

The decision variables and input parameters are described in Table 1.

Table 1: Decision variables and parameters.

Decision Variables	Description
$p_t$	Power (electricity) (for HVAC) purchased from grid at time $t$ [kW]
$g_t$	Power (electricity) generated by generator at time $t$ [kW]
$s_t^{in}$	Power charged by ESS at time $t$ [kW]
$s_t^{out}$	Power discharged from ESS at time $t$ [kW]
$T_{t,z}^{sp}$	Zone set point at time $t$ [°C]

---

Parameters	Description
$C_t^e, C^g$	Cost of grid purchased electricity, natural gas purchased [\$/kWh]
$G^e, G^g$	Cost related to GHG emission rate of electricity and natural gas [\$/kWh]
$\lambda^s, \lambda^d, \lambda^g$	Efficiency of energy charge, discharge to/from ESS and on-site generation
$\alpha_1, \alpha_2, \alpha_3$	Weight of cost, GHG emission cost and occupant comfort deviation
$T_t^{zone*}$	Target temperature of zone
$T_{t,z}^{zone,L}, T_{t,z}^{zone,H}$	Lower and upper bounds for zone temperature at time $t$ for zone $z$

Our optimal control method determines a profile of a control variable, e.g., set point of zone  $z$  and time  $t$  for a future time horizon (e.g., next 24 hours) that minimizes total energy costs of operating HVAC system subject to zone thermal behavior (Equation 6 and 7) in a building, energy balance (Equation 8) in a zone, comfort bounds for zone temperature (Equation 9) and physical limitations of the equipment, i.e. HVAC system, ESS and EGS. Our optimization model takes into consideration demand response signal (dynamic pricing profile of grid electricity for next 24 hours), capacity and costs of on-site ESS, and on-site EGS, and attempts to satisfy the thermal comfort (e.g., zone temperature and humidity). The objective (Equation 5) is to minimize the total cost. This includes (but is not limited to) the costs related to energy usage, greenhouse gas emission, and deviation from comfort temperature range for building occupants. The details of the physical constraints for ESS and EGS are omitted here. Our approach optimally computes how much electricity to purchase from grid, how much to generate on-site and how much to store on-site, and how much of the stored or generated electricity to use for the operations of HVAC system. The approach simultaneously computes the optimal control profile of HVAC system and the optimal way to power the HVAC system from the multiple sources.

In this paper, we simplify the MINLP by using linear transfer functions (hardlims or satlins), which results in MILP. This MILP can be solved using a variety of methods, depending on its size. One way to solve the MILP problem is with the IBM-ILOG CPLEX solver (IBM-ILOG CPLEX 2014).

## 5 INITIAL RESULTS AND DISCUSSION

Here we present a preliminary optimal solution for a zone for a day in August, shown in figure 5, 6 and 8. We then compare the energy cost and savings of the optimal solution with two traditional HVAC control strategies: a night setup and demand limiting strategy (Braun, Montgomery and Chaturyedi 2001; Lee and Braun 2004). For the night setup strategy, the temperature set point profile is prescribed as 24°C during

5AM – 9PM and 26.7°C during 9PM – 5AM. For the demand limiting strategy, the set point profile is 22.5°C during 5AM – 1PM, 25.5°C during 1PM – 9PM, and 26.7°C during 9PM – 5PM. The CPLEX solver was stopped prior to termination: this means that we cannot guarantee global optimality. Empirically, this is a reasonably good, feasible solution. We are evaluating various formulations of the optimization problem and solution methods to obtain robust and good solution, this work is still in progress. For this scenario, we used satlins as the transfer function of NARX model, and 48 time steps for 24 hours period (i.e., 30 minutes interval).

The scenario is for a day in August; therefore, the energy consumption here is only for cooling.

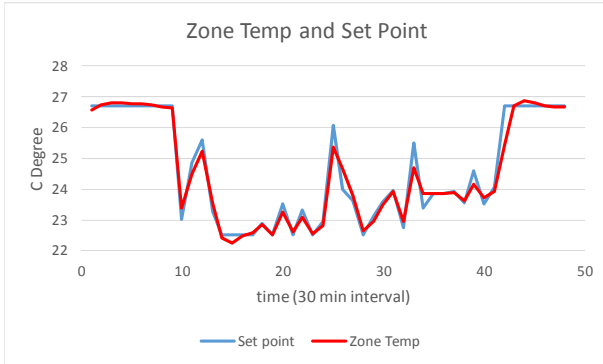

Figure 3: Optimal set point and zone temperature.

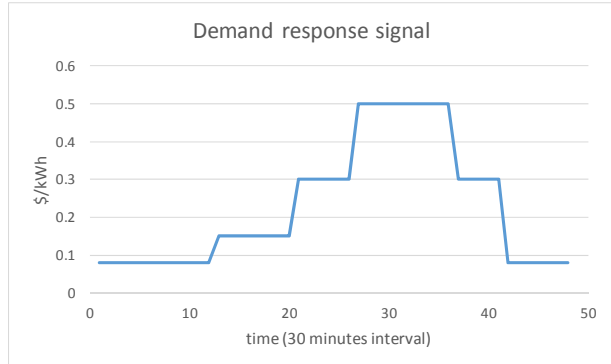

Figure 4: Demand response signal.

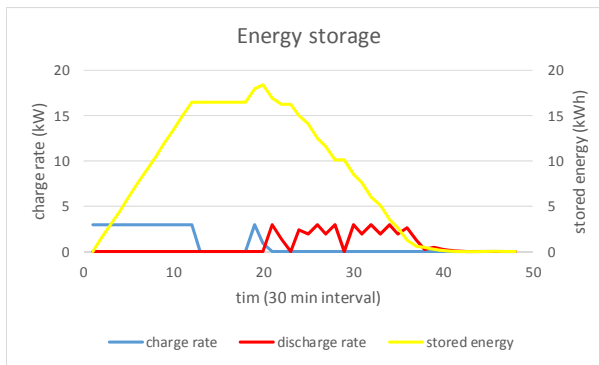

Figure 5: Charge, discharge, storage of ESS.

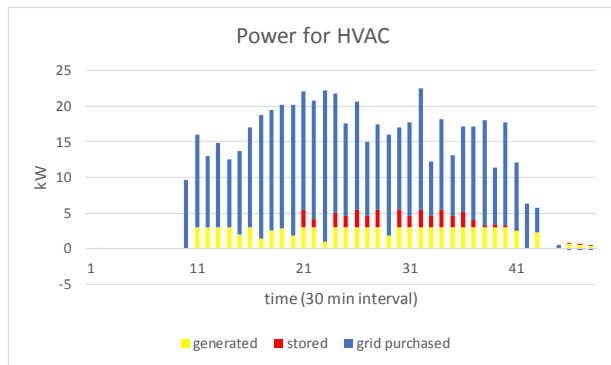

Figure 6: Energy for powering HVAC.

Table 2: Energy cost and saving for optimal control profile with respect to other control strategies.

	Night setup (Base)	Demand Limiting	Optimal without ESS and EGS	Optimal with ESS and EGS
Cost	\$98.11	\$83.14	\$84.13	\$67.74
Saving	---	15.26%	14.25%	30.95%

Figure 3 shows the optimal control profile (i.e. set point temperature of a zone) and corresponding zone temperature in 24 hours period in 30 minutes time intervals. The set point during the night period (9PM – 5AM) was kept at 26.7 °C by the model by assuming that free cooling can be obtained through ventilation during the night time. The DR signal, i.e. dynamic grid energy price is assumed to be

available in hourly resolution for next 24 hours, and is updated in every hour. The demand response signal profile for this scenario is presented in Figure 4, where the price is ranged from \$0.08/kWh to \$0.5/kWh during a day. Figure 3 illustrates that the set point is relatively low in morning hour when the electricity price is low, and high when the price is higher. Figure 6 shows the total electricity required to power the HVAC system (in this case, cooling) and sourcing of the total energy to the grid purchase electricity (blue line), on-site generated energy (yellow line) and on-site stored energy (red line). In this simplified scenario, it is assumed that the maximum generation rate for a zone is 3kW, maximum charge rate/discharge rate is 3kW, and the efficiency of charging and discharging are 85% and 80% respectively. The charge rate, discharge rate and the accumulated energy of ESS is shown in Figure 5. Note that electricity is charged to ESS when the DR signal is low and discharged when it is high.

The total cost for powering the HVAC system for the scenario is \$67.74, which is a saving of 30.95% with respect to the night setup (base case) control strategy (also simulated with the same NARX model). Even when it is assumed that all the electricity needed is sourced from grid purchased electricity (i.e. without ESS and EGS), the cost is \$84.13, which is 14.25% savings with respect to the base case and similar to the cost for demand limiting strategy (but with different zone temperature profiles) as summarized in table 2.

## 6 CONCLUSION

We developed a method for computing the optimal control of building's HVAC system as demand response tool by taking into consideration dynamic demand response signal, on-site energy storage system and on-site energy generation system using NARNET and MINLP. The NARNET accurately predicts the thermal behavior of the building/HVAC system, and is used for simulating various HVAC control strategies. The MINLP is hard to solve, and we are developing a novel approach to reduce the problem size and find the global optimal solution in reasonable computation time. We are working towards being able to compute the optimal HVAC control profile for multi-zones, for day ahead in 10 minutes intervals and communicate the control profile to building automation system (BAS) in real time.

## REFERENCES

- Anderson, J. 1995. *An Introduction to Neural Networks*. MIT Press, Cambridge, MA.
- Braun, J. E., K. W. Montgomery, N. Chaturvedi. 2001. "Evaluating the Performance of Building Thermal Mass Control Strategies." *HVAC & Research* 7(4):403–428.
- Braun, J. E. 1990. "Reducing Energy Costs and Peak Electricity Demand Through Optimal Control of Building Thermal Storage." *ASHRAE Transactions* 96(2):876–888.
- EnergyPlus. 2015. <http://apps1.eere.energy.gov/buildings/energyplus/>, 2015.
- IBM-ILOG CPLEX 12.6 User's Manual. 2014. IBM.
- Kusiak, A., G. Guanglin. 2012. "Modeling and Optimization of an HVAC System using a Dynamic Neural Network." *Energy* 42 (2012) 241-250.
- Lee, K., J. E. Braun. 2004. "Development and Application of an Inverse Building Model for Demand Response in Small Commercial Buildings," *SimBuild, IBPSA-USA National Conference*, August 2004.
- NREL. 2008, <http://www.nrel.gov/docs/fy08osti/43156.pdf>.
- Zavala, V. M., S. T. Celinski, P. Dickinson. 2011. "Techno-Economic Evaluation of a Next-Generation Building Energy Management System." Technical Report ANL/MCS-TM-313, Argonne National Laboratory.
- Zavala, V. M, T. M. Zimmerman, A. Ott. 2011. "Next-Generation Building Energy Management Systems and Implications for Electricity Markets." Technical Report ANL/MCS-TM-315, Argonne National Laboratory.



## **AUTHOR BIOGRAPHIES**

**YOUNG M. LEE** is a Research Staff Member and an IBM Master Inventor in the Business Solutions and Mathematical Sciences Department of IBM's T.J. Watson Research Center, U.S.A. Dr. Lee received B.S., M.S., and Ph.D. degrees in chemical engineering from Columbia University. He joined the IBM Research Division in 2002, and has been working in various mathematical modeling projects in the areas of energy management, supply chain, manufacturing and service sciences and developed numerous simulation and optimization models for both IBM and external clients. Prior to joining IBM, he had worked for BASF for 14 years, where he had founded and managed the Mathematical Modeling Group, and led development of numerous optimization and simulation models for various manufacturing and logistics processes. His research interest includes modeling, simulation and optimization of energy performance of buildings and manufacturing plants, supply chain management, manufacturing processes, services, workforce management, business processes and emergency response operations. His email address is [ymlee@us.ibm.com](mailto:ymlee@us.ibm.com).

**RAYA HORESH** is a Research Staff Member in the Business Solutions and Mathematical Sciences Department of IBM's T.J. Watson Research Center, U.S.A. Dr. Horesh received B.Sc. in physics and electro-optics from Ben-Gurion University in Israel and Ph.D. in applied mathematics from Emory University in Atlanta, GA. After spending one year as industrial post-doc at Institute for Mathematics and Its Applications (IMA) at University of Minnesota (jointly with IBM Research), she joined IBM Research in 2011. Since joining IBM, Dr. Horesh has been working on various modeling, optimization and data analytics projects both for IBM and for external clients. Her research interest include physics and data driven based modeling, non-linear large scale optimization, inverse problems, numerical differential equations and numerical analysis. Her email address is [rhoresh@us.ibm.com](mailto:rhoresh@us.ibm.com).

**LEO LIBERTI** is a Research Director at CNRS and a professor at Ecole Polytechnique (France). He obtained his Ph.D. at Imperial College, and became a professor at Ecole Polytechnique in 2006. During 2012-2014 he was a Research Staff Member at the Mathematical Sciences Department of the IBM TJ Watson Research Lab in U.S.A. He is editor-in-chief of the Springer journal "4OR", and associate editor of many other journals. His main research interests are mathematical optimization and distance geometry. His email address is [liberti@lix.polytechnique.fr](mailto:liberti@lix.polytechnique.fr).