

ELIMINATE BOTTLENECKS WITH INTEGRATED ANALYSIS TOOLS IN eM-PLANT

Matthias U. Heinicke

Tecnomatix Technologies
Mittlerer Pfad 9
Stuttgart, D-70499, GERMANY

Alan Hickman

Tecnomatix Consulting
PTMC, Marsh Lane
Preston, PR1 8UD, UNITED KINGDOM

ABSTRACT

To build a realistic simulation model is all very well - to add real value you must identify the major difficulties and generate better alternatives. Tecnomatix Technologies, developers of eM-Plant, the object oriented simulation tool for discrete event simulation, planning and optimization of production and logistics, are the world leaders of the e-Manufacturing market. eM-Plant is used across many industries from manufacturers like BMW and Daimler-Chrysler through shipyards to international finance. Experience from all these areas inspired the development of analysis and optimization tools as an integral part of the simulation objects that continuously monitor and evaluate the operation of each simulation object and its interactions at a local and global level. Thus, for example, bottlenecks in a material flow are automatically detected and Sankey diagrams generated. This object based approach fits closely with the object-oriented nature of eM-Plant that allows unprecedented accuracy and re-usability in simulation modeling. These analysis tools work with global evaluation wizards which, for example, make it simple to create specific Gantt-charts etc., and using Genetic Algorithms modules the simulation system can even propose better layouts or operating strategies.

1 AUTOMATED BOTTLE NECK DETECTION

1.1 The Bottleneck Analyzer

All simulation objects in an eM-Plant model collect and analyze data for the bottleneck analyzer. After running a simulation for any length of time, existing bottlenecks can be identified at once using the bottleneck analyzer object, which also gives a graphical representation of the utilization at each resource. No external statistical analysis is required and the results are valid for any simulation model regardless of global or local structure. Note that two kinds of bottlenecks are identified and illustrated in figure 1.

1.2 High Utilization Bottleneck

The utilization is too high, i.e. the utilization of the machines is between 90-100%, this kind of capacity bottleneck is shown in the ranking list of the bottleneck analyzer.

1.3 Failure Distribution Dependent "Bottleneck"

Elements with a high waiting percentage (shown in the Simulation model as length of bars) are ready to process, but cannot because of missing materials, elements with high blocking percentages shown graphically with yellow bars: stations want to move materials, but cannot because of the bottleneck. Most of the time this kind of operational "bottleneck" is caused by failures, maintenance, pauses, set-up times or shift changes.

2 MATERIAL FLOW VISUALIZATION IN SANKEY DIAGRAMS

Each simulation object also collects the required data to produce a Sankey diagram. This is generated at the touch of a button allowing you to immediately visualize material flows in any simulation model and identify any transportation or logistical problems. The material flows are illustrated in Figure 2.

3 GANTT WIZARD

eM-Plant simulation objects can gather detailed state time information making the construction of a Gantt chart view straight forward for any simulation model. Using a Gantt wizard the user can easily configure the Gantt view selecting either an order or a resource based view. This can be particularly useful in online simulation systems showing the flow of real current orders through a plant.

4 DYNAMIC SCHEDULING/ROUTING

Given the detailed information and analysis at each object in an eM-Plant model it is possible to introduce customized

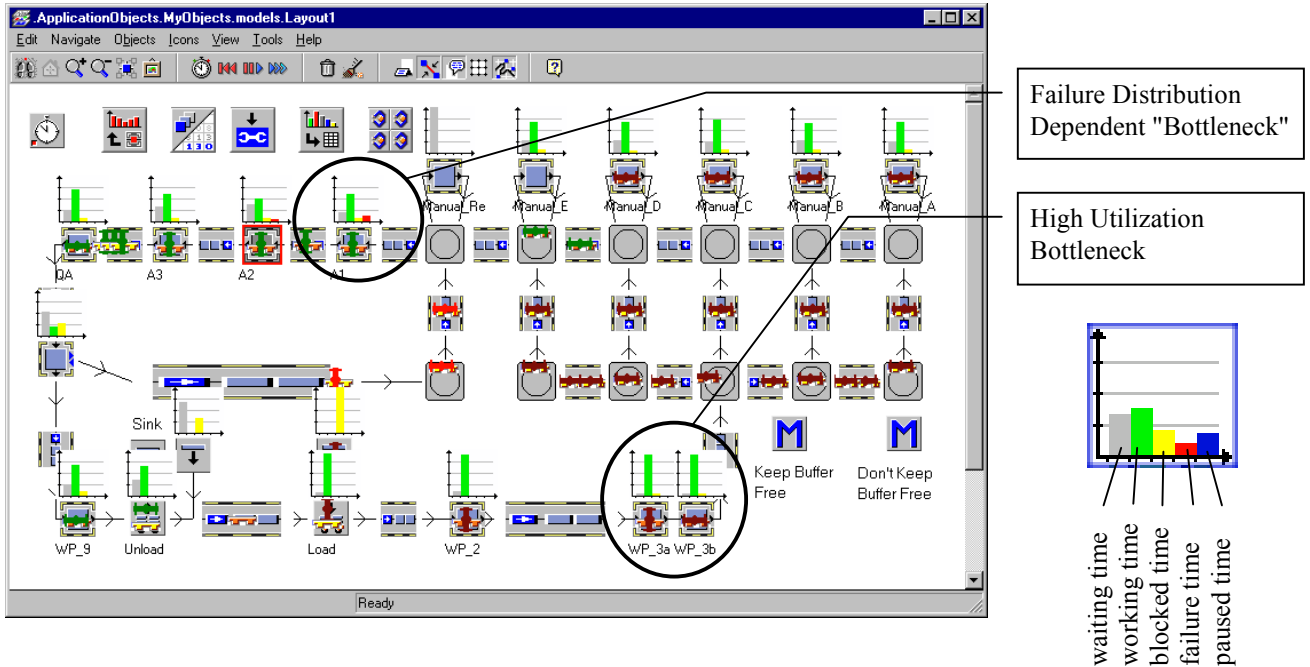

Figure 1: eM-Plant Model Showing Bottleneck Detection

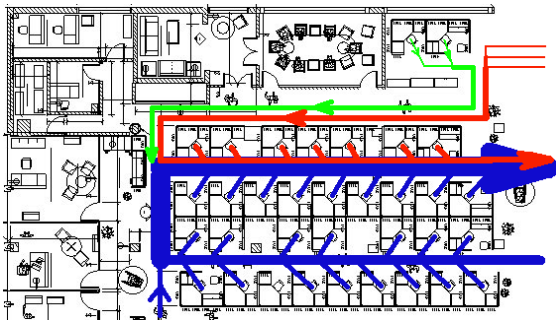

Figure 2: Sankey Diagram of Material Flows



Figure 3: Gantt Chart

5 GENETIC ALGORITHMS

In addition to allowing the implementation of dispatch techniques the structure of eM-Plant also facilitates global planning and scheduling techniques, for example eM-Plant Genetic Algorithm objects. Genetic algorithms are iterative search algorithms closely following mechanisms of natural evolution (Davis 1991). Their search for an optimal solution is both efficient and robust. They are efficient in using every result to guide the search towards an optimal solution. They are robust, because only one overall fitness function (provided by an eM-Plant simulation model) is used to evaluate the quality of a solution. Thus, many and even conflicting goals can be considered e.g. removing bottlenecks versus resource costs. Genetic algorithms can be used in conjunction with an eM-Plant simulation model for a wide range of strategic problems...

- Layout design
- Capacity planning
- Operations optimization

In day-to-day operations Genetic Algorithms produce solutions for:

- Resource management
- Sequence planning
- Route planning
- Lot size optimization

scheduling/routing controls at any number of points in the material flow, these types of objects exist in a number of industry specific eM-Plant Application Object Libraries. Dispatching can be based on a combination of simulation results allowing for example bottleneck optimization or other scheduling strategies to be dynamically implemented. A number of common default strategies are available at the touch of a button using standard eM-Plant building blocks.

A theoretical method is only as good as its practical application and eM-Plant provides the ideal structure for implementation of these methods. Currently Genetic Algorithms can be applied to three types of combinatorial tasks: sequencing, allocating and selecting. The above practical problems just represent a combination of one or more of these basic tasks. Just as an individual is characterized by a set of chromosomes, a solution based on genetic algorithms can be said to consist of a set of solutions of the combinatorial basic tasks.

The genetic algorithm objects are dropped into the simulation model used to evaluate them and connected by a few, clearly structured interfaces that allow a logical mapping from the global solution to the individual objects in the model. Meanwhile, the appropriate evaluation and analysis components of the eM-Plant model can provide all the information required for the solutions evaluation - the overall fitness function. For each basic task the genetic operators used can be defined with varying probabilities. These probabilities can be changed at each step of the optimization process.

On the one hand, these technologies make it easy to realize an optimization on the basis of empirical values. On the other hand they allow an exact analysis of the specific properties of the optimization problem. User-friendly evaluation tools and pre-prepared interface components make it possible to observe the exact course of the optimization, which the user is able to influence interactively through the selection of the genetic operators used, their operating parameters and the relevant selection algorithms (Nissen 1997).

6 DATAFIT: STATISTICAL DATA EVALUATION

eM-Plant Datafit is a statistical analysis package integrated into the eM-Plant environment in the form of eM-Plant objects. Accurate statistical analysis is central to the validity of any simulation project (Law and Kelton 1991). The following Application Objects are provided:

Distribution Fitting

- Filtering Samples and Descriptive Statistics
- Estimators of the parameters of selected distributions
- Goodness-of-fit tests
- Histograms

Confidence Intervals

Linear Regression Analysis

- Correlation Coefficient
- Regression Coefficient
- Regression Line
- Confidence Intervals
- Scatter Diagrams

Polynomial Regression Analysis

- Correlation Coefficient
- Regression Coefficient
- Regression Function
- Scatter Diagrams

Determining Parameters of Bounded Distribution

- Calculating parameters for given bounds and mean values
- Estimate the number of trials by the generation of the random number
- Density function plot of the truncated distribution

Analysis of Variance

- Test whether grouped data have equal mean values
- Graphical comparison of the confidence intervals of the groups

7 EASE OF USE

As described above, integrated analysis tools in eM-Plant allow a simulation model to be used to produce powerful results, but just as important these developments allow very quick, easy and relevant analyses to be performed.

REFERENCES

- Davis, L. 1991. *Handbook of Genetic Algorithms*. Thomson Computer Press.
- Law, A. M., W. D. Kelton. 1991. *Simulation Modeling and Analysis*. Singapore: McGraw-Hill, Inc.
- Nissen, V. 1997. *Einführung in Evolutionäre Algorithmen*. Braunschweig. Wiesbaden: Vieweg.

AUTHOR BIOGRAPHIES

MATTHIAS U. HEINICKE works in the Marketing Department of Tecnomatix Technologies GmbH & Co. KG in Stuttgart. He received a B.S. degree in economic engineering from the University of Kaiserslautern and worked for two years as a sales engineer for the simulation tool SIMPLE++ and eM-Plant. His email address is <heinicke@emplant.de>.

ALAN HICKMAN works for the consulting division of Tecnomatix Technologies in the UK, specializing in the implementation of projects and applications using eM-Plant. He studied Physics (BSc hon) at the Victoria University of Manchester (UK) and Computing (MSc) at the Metropolitan University of Manchester. His email address is <alan@aesop.co.uk>.