

ANALYSIS OF THE VIRTUAL ENTERPRISE USING DISTRIBUTED SUPPLY CHAIN MODELING AND SIMULATION: AN APPLICATION OF e-SCOR

Michael W. Barnett
Charles J. Miller

Gensym Corporation
125 CambridgePark Drive
Cambridge, MA 02140, U.S.A.

ABSTRACT

Supply chains are large systems consisting of many entities interacting in complex ways. The challenge faced by companies is how to design and manage such systems. Modeling and simulation enables analysis of complex systems but as the model increases in size and realism, or when it is necessary to locate model components geographically, a distribution capability is needed. The High Level Architecture (HLA), developed by the Department of Defense provides the infrastructure needed for large-scale distributed simulation. The supply chain management field is characterized by a lack of standards and definitions. The Supply Chain Council has established a standard way to examine and analyze supply chains with their Supply Chain Operations Reference, or SCOR model. The SCOR model provides a standard way of viewing a supply chain, a common set of manipulate-able variables and a set of accepted metrics for understanding the dynamic behavior of supply chains. The e-SCOR modeling and simulation environment is based on SCOR and adds discrete event simulation capabilities. This paper describes the architectural components used to implement a distributed supply chain modeling tool (e-SCOR) and applications of e-SCOR that demonstrate how enterprises are modeled and analyzed to determine the validity of alternative, virtual business models.

1 INTRODUCTION

Modern corporations are faced with the many challenges presented by adapting to business on the Internet. Executives acknowledge the importance of the new medium but are not sure how to take advantage of it. Access to more information, new channels for product, multiple alternatives for outsourcing and creation of an entirely virtual organization within and without the existing, traditional ways of doing business confound our ability to decide what is the best strategy for business improvement.

Two types of tools are employed to get a better understanding of appropriate business transformation alternatives. Optimization routines, such as those based on CPLEX are helpful when mechanisms can be abstracted in such a way that the essence of the problem is maintained and the underlying model complexity controlled. Simulations of mechanistic models of supply chain processes using discrete event simulators don't involve structured search for the optimum but have a rich description of the system, which can clarify the interpretation of results and improve understanding of cause-effect relationships.

Mechanistic process models of supply chains are large and complex. It will likely be necessary to distribute portions of these models to improve performance, manage computing resources and to support enterprise information systems that rely on the model for business process monitoring, workflow automation and management decision support. The High Level Architecture (HLA), developed by the Department of Defense provides the infrastructure needed for this type of large-scale distributed simulation.

In order to tackle the problem of generically representing supply chains, we need a standard to serve as a guide. The Supply Chain Council's Supply Chain Operations Reference (SCOR) model provides such a foundation. The Supply-Chain Council is an initiative by individuals representing several companies including Advanced Manufacturing Research, Bayer, Compaq Computer, Pittiglio Rabin Todd & McGrath, Procter & Gamble, Lockheed Martin, Nortel, Rockwell Semiconductor, and Texas Instruments.

2 ARCHITECTURE FOR A DISTRIBUTED SUPPLY CHAIN MODEL

Figure 1 shows how several supply chain models are combined within the HLA architecture to support distributed simulation. Each component or 'federate' participates in the simulation under the management of the federation executive (FedExec).

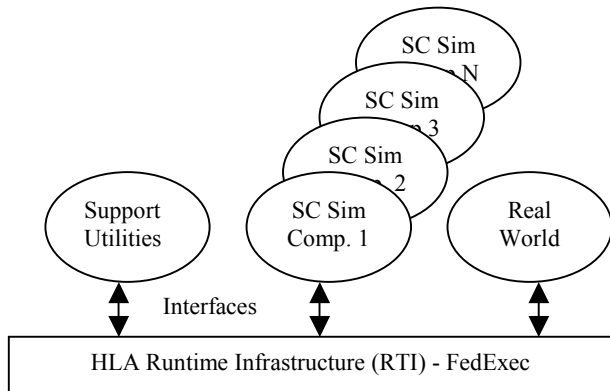

Figure 1: Distributed Supply Chain Architecture with HLA

e-SCOR, a supply chain modeling tool was used in this project. e-SCOR is an object-oriented process model development environment based on SCOR and layered upon a discrete event simulator. e-SCOR contains several functional drag-and-drop blocks used to construct models. The functional blocks can be grouped into four levels as shown in Table 1.

Table 1: Type of Model Building Blocks

Level	Description	Types of Block
1	Supply chain roles	Base Manufacturer, Manufacturer, Distributor, Consumer
2	Four essential management processes	Plan, Source, Make, Deliver
3	Process ‘categories’	17 pre-defined
4	Implementation	‘atomic’ business process blocks

Blocks at the lowest level map conveniently into the notational elements defined in the Unified Modeling Language for activity diagrams (Rumbaugh et.al 1999). A user builds a model of a supply chain using the level 1 or ‘Role’ block. If necessary, users can modify other levels to represent differences in implementation details. A large supply chain can be constructed from smaller components as shown in Figure 1. Each component or federate of the distributed supply chain model is constructed using these blocks.

A bridge between e-SCOR and the HLA was developed, including application program interfaces for all pertinent HLA procedures. The two essential capabilities needed to support a distributed simulation are time management and mechanisms for publishing and subscribing-to object attribute values in each federate.

2.1 Time Management

The HLA specification includes all the necessary mechanisms for managing time amongst the supply chain

model federates. In order to use these facilities, the main simulation loop in e-SCOR was modified to include statements that wait for simulation time advances, publish values subscribed to by other federates and retrieve values of attributes subscribed to by a federate. In pseudo-code, the main simulation loop is as follows;

```

repeat
  exit if time > max-time;
  request = call request-time-advance();
  wait until request is true;
  <manage block execution queues>
  publish values;
  request retrieval of subscribed-to values;
end
    
```

With this addition to the main simulation loop, any e-SCOR model can be time-synchronized with one or more additional e-SCOR models using the facilities provided by HLA.

2.2 Publish and Subscribe

In order to be able to exchange data between federates, it is necessary to employ the publish-and-subscribe mechanisms provided by the HLA. In e-SCOR, this is implemented as conventions for entering publish/subscription attributes in the user interface and a set of methods that call HLA procedures for;

1. object instance registration,
2. object/instance/attribute discovery,
3. attribute registration and update, and,
4. object/attribute de-registration.

Object interactions (as defined by HLA) were not implemented.

3 SIMULATING A VIRTUAL ENTERPRISE

Two applications that employ the HLA and the e-SCOR modeling and simulation system will be described.

3.1 Game Simulation

The first is a simple, distributed process model of a game in which an actor (called the ‘gamer’) requires decisions by a second federate (see Figures 2 and 3). Each federate has a different time step.

Both models consist of an ‘Initiate’ event, a single activity (Issue Commands or Decision) and a final state. The activities have additional detail in hierarchical levels below the top level shown in Figures 2 & 3 to represent their behavior. For example, the detail one level below “Issue Commands” is shown in Figure 4.

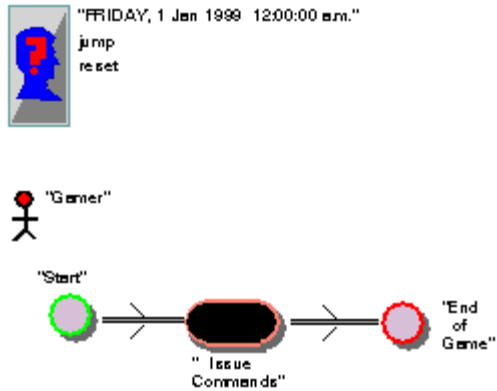

Figure 2: Federate that Requires a Decision in the Issuance of Commands

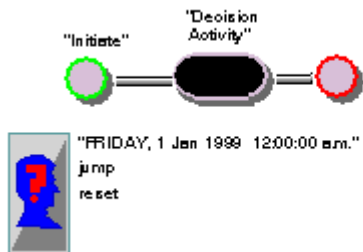

Figure 3: Federate Providing the Decision Activity

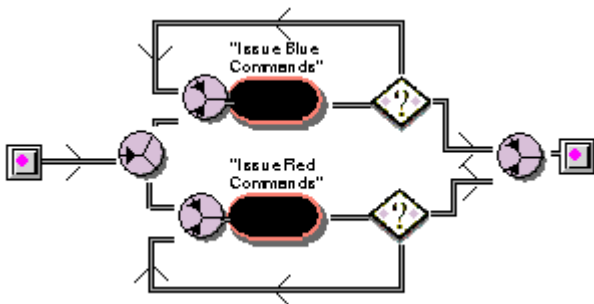

Figure 4: The "Issue Commands" detail

Federation time does not begin to advance until both federates complete initialization and acknowledge that they have achieved the synchronization point. As the simulation proceeds, commands are generated by the decision activity at a higher frequency so that the "Issue Commands" activity can benefit from the decisions. The HLA ensures that time for the federation advances appropriately.

3.2 e-SCOR Simulation

The second example demonstrates the application of the SCOR model within the HLA-enabled model development environment provided by e-SCOR. The supply chain

model is shown in Figure 5. The model (large blocks from left to right in Figure 5) consists of two base manufacturers, a distributor, a manufacturer, then a second distributor and two consumers. The lower consumer role is a planned, web channel for the manufacturer's products, whereas the upper consumer represents the manufacturer's current retail channel. Each of these blocks encapsulates extensive logic and business rules hierarchically below this top level. Any component of the model can be distributed amongst a federation of machines using the infrastructure described in Section 2.

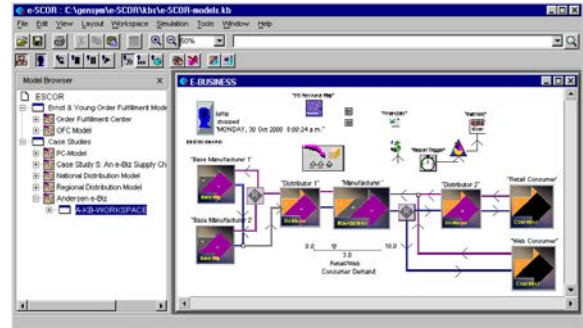

Figure 5: Simulating the Addition of a New Channel for Products

In the simulated scenario, the new channel is introduced, resulting in erosion of sales from the 'retail' channel. The small slider just below the manufacturer in Figure 5 is used to shift the demand from one channel to the other. This permits the manufacturer to examine the impact of introducing the new channel. Questions concerning the impact on revenues, inventory levels, and demand management can be answered prior to implementation of the plan.

The results of a two-year simulation during which demand was shifted from the Retail channel to the Web channel and back again is shown in the graph of Figure 6, which shows the total of bookings, outstanding, collections, obligations, and payments (in \$) for each of the five roles versus time.

The figure highlights the impact of introducing the web channel. The period in the center of the graph shows the elimination of Distributor 2 as the web channel is introduced.

SUMMARY

Current tools for discrete event simulation enable the development of large-scale models. These can be extended to represent - in a standard way - the dynamics of modern material supply or service supply chains. The SCOR model (<http://www.supply-chain.org/>) provides the process structure necessary to understand these systems and, together with the simulation technology in e-SCOR

(http://www.gensym.com/b2b_modeling/default.htm), permits the examination of alternative business models prior to implementation. To extend these models it is also necessary to distribute the model across a network. The DOD HLA (<http://www.dmsomil/portals/hla.html>) provides the required infrastructure. When combined, these technologies enable development of advanced applications in enterprise management including tools for improved design, real-time monitoring and control, optimization and decision support.

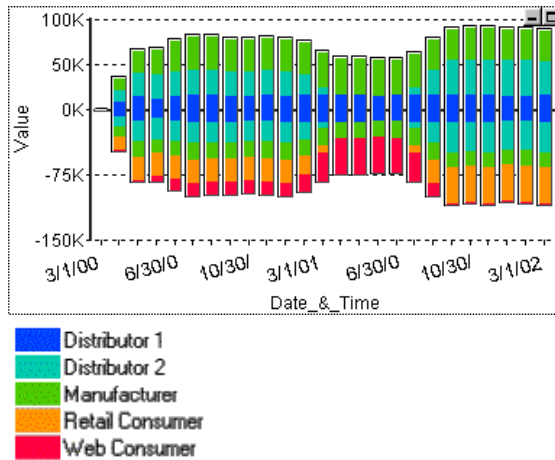

Figure 6: Results of the Two-Year Simulation

ACKNOWLEDGMENTS

The authors would like to acknowledge the support of the staff at Gensym who developed the infrastructure that enables distributed dynamic simulations using the HLA.

REFERENCES

Rumbaugh, J., Jacobsen, I and G. Booch 1999. *The unified modeling language reference manual*. Reading, MA: Addison-Wesley.

AUTHOR BIOGRAPHIES

MICHAEL W. BARNETT is a Managing Consultant at Gensym Corporation. He received his B.A. and M.S. degree from the University of Cincinnati and his Ph.D. from Rice University. His interests include modeling & simulation, electronic commerce and business process transformation. His email address is mwb@gensym.com.

CHARLES J. MILLER is a Senior Consulting Engineer at Gensym Corporation in the Advanced Systems Business Unit. He previously held positions at TRW Inc. working on applications in network management and large-scale simulation in business process transformation. His email address is cmiller@gensym.com.